

## Cabinet U-Handles

### Aluminum Die Casting

#### SPECIFICATION

##### Types

- Type **A**: Mounting from the back (threaded blind bore)
- Type **B**: Mounting from the operator's side

##### Aluminum die casting

- Plastic coated
  - Black, RAL 9005, textured finish **SW**
  - Silver, RAL 9006, textured finish **SR**
- Plain finish, tumbled **BL**

#### INFORMATION

The installation of cabinet U-handles GN 728 can be carried out from the back (type A) as well as from the operator's side (type B).

#### TECHNICAL INFORMATION

- Load Rating Information (see page A35)

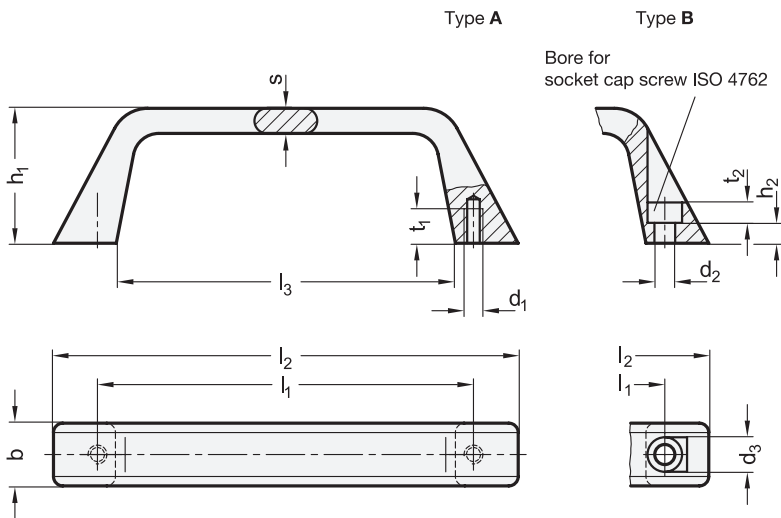

\* Complete with

SW
SR
BL  
 RAL9005    RAL9006    Plain finish

#### GN 728-A

Description	l <sub>1</sub>	b	d <sub>1</sub>	h <sub>1</sub>	l <sub>2</sub>	l <sub>3</sub>	s	t <sub>1</sub> min.	⚖
GN 728-120-A-*	120	22.5	M 6	42.5	147	108	8	10	93
GN 728-180-A-*	180	27	M 8	47.5	214	165	10	12	194

#### GN 728-B

Description	l <sub>1</sub>	b	d <sub>2</sub>	d <sub>3</sub>	h <sub>1</sub>	h <sub>2</sub>	l <sub>2</sub>	l <sub>3</sub>	s	t <sub>2</sub>	⚖
GN 728-120-B-*	120	22.5	6.4	11	42.5	6.5	147	108	8	6.5	83
GN 728-180-B-*	180	27	8.4	13.5	47.5	7.5	214	165	10	8.5	172

Weight SW

